

Note:

Use the illustration on the next page as a reference to the text. It is important to note that you must adjust the high-pressure setting on the relief valve **before** adjusting the low-pressure setting. Adjusting the high-pressure setting after the low-pressure setting actually changes the low-pressure setting, hence you must adjust the low-pressure setting again.

("High-Pressure" Adjustment Procedure)

1. Supply 80 psi to 435 psi into the pilot port at the end of the relief valve. This will shift the relief valve to the high-pressure setting.
2. Actuate the function and record the motor workport pressure (**Note: Motor must be loaded enough to open the relief valve**). This is the high-pressure setting on the VD20-03 relief valve. To adjust:
 - a. Remove the relief valve from the motor.
 - b. Disassemble the relief valve to gain access to "SHIMS PSCH 1":
 - remove the "End Cap"
 - remove the "Plunger"
 - remove "SPRING DF 1"
 - c. Add shims to increase the relief valve setting or remove to decrease.
(HINT: 0.1mm shim = 340 psi change)
 - shim part number 9289003019 = 0.25mm
 - shim part number 9289003017 = 0.10mm
 - d. Reassemble the relief valve:
 - reinstall the "Plunger" making sure to capture all springs and shims
 - reinstall the "End Cap" and torque it to 59 ft-lb, making sure that the o-ring is properly positioned
 - reinstall the relief valve into the motor and torque it to 59 ft-lb
3. Repeat steps #1 and #2 until the desired high-pressure setting is acquired.

("Low-Pressure" Adjustment Procedure)

4. Make sure that the pressure in the relief valve pilot port is less than 80 psi. It is recommended that there be no pressure in this pilot port.

5. Actuate the function and record the motor workport pressure (**Note: Motor must be loaded enough to open the relief valve**). This is the low-pressure setting on the VD20-03 relief valve. To adjust:
- Use the special tool to loosen the jam nut on the "SCREW".
 - Turn the "SCREW" in to increase the low-pressure setting or out to decrease it.
 - If you cannot acquire the desired setting, you may have to add/remove "SHIMS PSCH 2".
 - HINT: 0.1mm = 6.5 psi
 - shim part number 9289003201 = 0.5mm
 - shim part number 9289003197 = 0.1mm
 - Follow the instructions in step #2 to gain access to "SHIMS PSCH 2".
 - Once the desired low-pressure setting is acquired, tighten the jam nut.

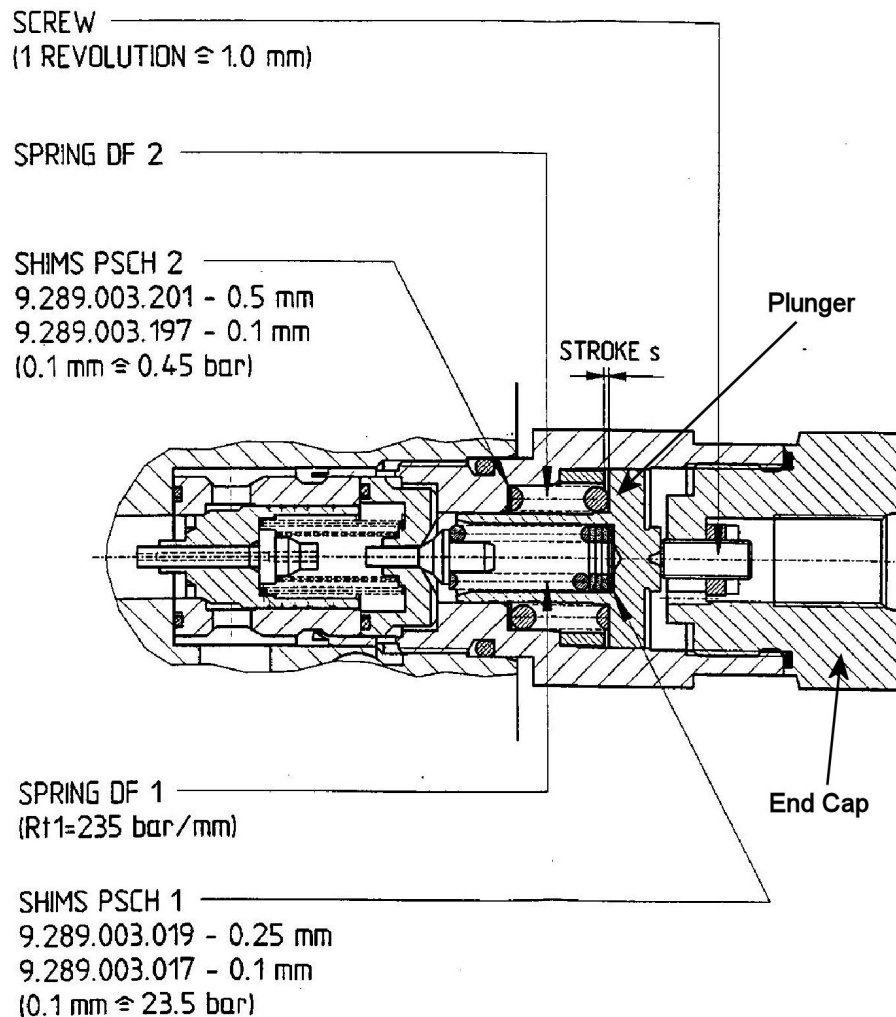



*******ATTENTION*******

You have been provided information on conversion, repair and/or service of Linde components. Proper application of the information requires specific training and may require use of specialized tooling and equipment. If you choose to proceed with the conversion, repair and/or service of the Linde component(s) absent the necessary training and/or these specialized tools, you do so at your risk.

Linde Hydraulics Corporation will accept no claim for warranty or other consideration resulting from deficiencies in the conversion, repair and/or service done in accordance with the guidance offered herein when the necessary training has not been conducted and/or required specialized tooling and equipment has not been utilized.

All requests for training must be coordinated through your Linde Account Manager. He can also provide you price and availability of any specialized tooling.

Questions regarding the information provided or this disclaimer should be addressed to the Warranty & Service Department, Linde Hydraulics Corporation.

5089 Western Reserve Road

Canfield, OH 44406

330.533.6801 (Telephone)

330.533.9873 (Facsimile)

www.lindeamerica.com (Web Site)