

Side-Ported HMV-02 with Hydraulic Infinitely Variable Control

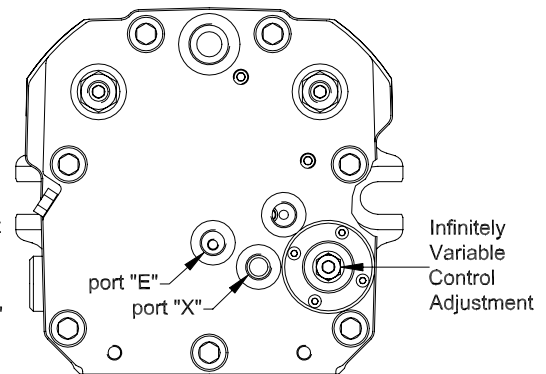

Side-Ported HMV-02 with Hydraulic Infinitely Variable Control

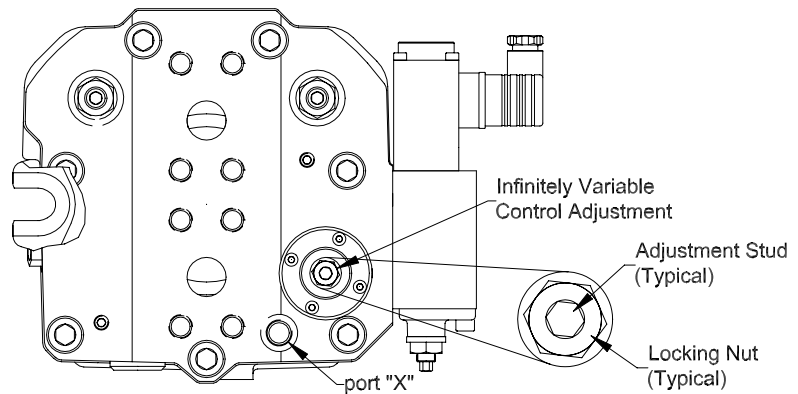

Rear-Ported HMV-02 with Hydraulic Infinitely Variable Control and Pressure Compensator

IMPORTANT:

This procedure does not include the “H6” or “E6” Control option. For “H6” or “E6” Control Adjustment Procedure, please refer to the related Linde Service Bulletin.

Tools/Equipment Required:

Note: Due to slight differences in the HMV-02 controls and motor sizes, several tools will be specified to insure that you have all tool combinations that may be required.

- 13mm off-set closed-end wrench
- 17mm wrench
- 6mm wrench
- 5mm Allen wrench
- 4mm Allen wrench
- 0-400 psi pressure gauge (optional: 0-400 psi pressure transducer)

Note #1:

Make sure that the HMV-02 minimum and maximum displacements have been adjusted prior to performing this procedure. Refer to Related Service Bulletins for information on how to make these adjustments.

Note #2:

To insure the proper operation of the motor, you must provide supply-pressure into port "E" between 290-580 psi. If the HMV-02 has the configuration where this supply-pressure is provided internally (via the case-flushing shuttle), then ignore this note.

Note #3:

Prior to performing this procedure, it is necessary for you to know what the control range is for your particular HMV-02. The HMV-02 motors can be equipped with spring packages that provide several different control ranges.

Note #4:

The spring package that the HMV-02 is equipped with will provide a control range that **cannot** be adjusted. The only thing that can be adjusted is either the regulation begin setting or the regulation end setting.

EXAMPLE: If the HMV-02 has a spring package to provide a control range of 87 psi (116 psi regulation begin and 203 psi regulation end), then this control range cannot be changed. If you adjust the regulation begin from 116 psi to 100 psi, then the regulation end will automatically be changed from 203 psi to 187 psi.

If you need to change the control range, then you must consult Linde Engineering for the new spring package.

Note #5:

The HMV-02 motor automatically defaults to maximum displacement and will remain at maximum displacement unless supplied with an external pressure or power supply to force it to destroke. For a "hydraulically" controlled HMV-02 motor, control pressure is typically supplied into port "X" of the motor to destroke it.

When making the adjustment to the HMV-02 infinitely variable control, the HMV-02 will be at maximum displacement prior to the regulation begin setting. At the regulation begin setting, the HMV-02 will start to destroke towards minimum displacement. The HMV-02 will detroke linearly throughout the control range as the pressure at port "X" is increased.

For this procedure, the supply flow to the motor must remain constant throughout the adjustment procedure - The motor rotational speed will increase as the motor destrokes towards minimum displacement when the supply flow is constant. Therefore, for this procedure, the motor rotational speed will be used as the indicator to determine where the regulation begin and/or regulation end settings are.

Procedure for Adjusting the HMV-02 Hydraulic Infinitely Variable Control:

1. Install the 0-400 psi pressure gauge into port "X".
2. Start the prime mover and adjust it to operating speed.
3. Supply a constant flow to the HMV-02. As mentioned previously, maintain this constant flow throughout this procedure.
4. Slowly increase the control pressure into port "X".
5. Simultaneously monitor the pressure at port "X" and the rotational speed of the HMV-02.
6. When the rotational speed of the HMV-02 increases, record the pressure at port "X". This is the regulation begin pressure.
7. Continue to increase the control pressure into port "X". The rotational speed of the HMV-02 should continue to increase as the control pressure increases.
8. Verify that the regulation end point coincides with the control range for the spring package in your HMV-02 (as described in Notes #3 and #4 above).
9. Supply full control pressure into port "X". Confirm that the HMV-02 is at minimum displacement by checking the rotational speed of the HMV-02.
10. To adjust the infinitely variable control:
 - a. Hold the adjustment stud stationary.
 - b. Loosen the locking nut.
 - c. Turn the adjustment stud **IN** to **decrease** the regulation begin setting or turn it **OUT** to **increase** the regulation begin setting.
 - d. Once the desired regulation begin setting has been acquired, hold the adjustment stud stationary and tighten the locking nut.
11. Turn the prime mover OFF and remove the pressure gauge from the motor.

ATTENTION

You have been provided information on conversion, repair and/or service of Linde components. Proper application of the information requires specific training and may require use of specialized tooling and equipment. If you choose to proceed with the conversion, repair and/or service of the Linde component(s) absent the necessary training and/or these specialized tools, you do so at your risk.

Linde Hydraulics Corporation will accept no claim for warranty or other consideration resulting from deficiencies in the conversion, repair and/or service done in accordance with the guidance offered herein when the necessary training has not been conducted and/or required specialized tooling and equipment has not been utilized.

All requests for training must be coordinated through your Linde Account Manager. He can also provide you price and availability of any specialized tooling.

Questions regarding the information provided or this disclaimer should be addressed to the Warranty & Service Department, Linde Hydraulics Corporation.

5089 Western Reserve Road
Canfield, OH 44406
330.533.6801 (Telephone)
330.533.9873 (Facsimile)
www.lindeamerica.com (Web Site)