

IMPORTANT CHANGE

Linde has developed a new generation of charge pumps (UNI-DIRECTIONAL) for clockwise rotation HPV-02 pumps.

- This change is valid for **16cc & 22.5cc** charge pumps with **DIN** or **ISO** metric porting.
- These charge pumps **cannot** be converted to counterclockwise rotation.
- These charge pumps can only be converted between internal and external suction configuration (refer to Linde Conversion Bulletin "Procedure to Change Rotation on HPV-02 Pumps")

Please Note: The counterclockwise rotation charge pumps are still available as *BI-DIRECTIONAL* and can be converted to clockwise rotation.

Parts required for charge pump conversion:

Part Type	Part Number
Internal Suction / Clockwise Rotation Induction Plate	581 306 1306
Internal Suction / Counterclockwise Rotation Induction Plate	581 306 1308
External Suction Induction Plate (This is valid for either rotation)	581 306 1307
Needle Bearing (This is not supplied as part of the induction plate)	000 924 8036

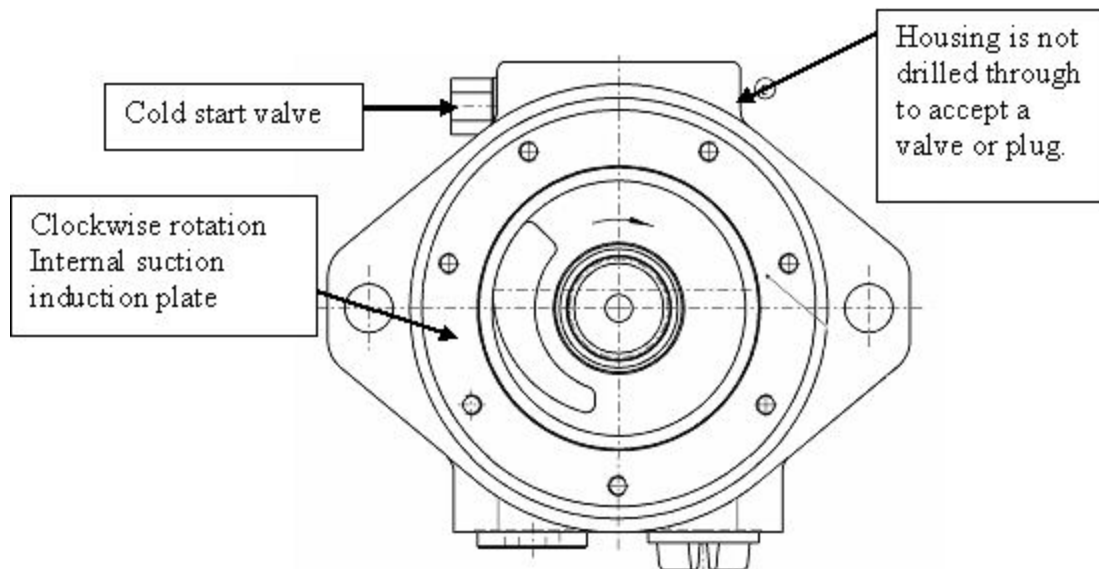



HPV-02 Charge Pump Configuration Change

Document No: 894

Rev. 0

Service Bulletin

Page 2 of 4

UNI-DIRECTIONAL CHARGE PUMP PART NUMBERS

HPV75 - 135

Part number	CC	Suction is :	Porting is :	PTO is :
581 300 1020	22.5	External	DIN- 26x1.5	"A"
581 300 1021	22.5	External	DIN- 26x1.5	"B-C"
581 300 1022	22.5	External	ISO- 27x2	"A"
581 300 1023	22.5	External	ISO- 27x2	"B-C"
581 300 1050	22.5	Internal	DIN- 26x1.5	"A"
581 300 1052	22.5	Internal	DIN- 26x1.5	"B-C"
581 300 1054	22.5	Internal	ISO- 27x2	"A"
581 300 1056	22.5	Internal	ISO- 27x2	"B-C"

UNI-DIRECTIONAL CHARGE PUMP PART NUMBERS

HPV55 ONLY

Part number	CC	Suction is :	Porting is :	PTO is :
580 300 1065	16	External	DIN- 26x1.5	"A"
580 300 1066	16	External	DIN- 26x1.5	"B-C"
580 300 1067	16	External	ISO- 27x2	"A"
580 300 1068	16	External	ISO- 27x2	"B-C"
580 300 1050	16	Internal	DIN- 26x1.5	"A"
580 300 1052	16	Internal	DIN- 26x1.5	"B-C"
580 300 1054	16	Internal	ISO- 27x2	"A"
580 300 1056	16	Internal	ISO- 27x2	"B-C"

Prepared By: Charles Coleman

Date: 9/28/2004



HPV-02 Charge Pump Configuration Change

If a rotation change is required; charge pump must be replaced as a complete assembly.

Replacement charge pump part numbers.

- All parts below are 22.5cc
- Used on HPV75 -135-02 frame sizes
- All parts below are Bi-directional (right **or** left handed)

Part number	Suction is :	Porting is :	PTO is :
581 300 1058	External	DIN -26x1.5	“A”
581 300 1059	External	DIN- 26x1.5	“B-C”
581 300 1060	External	ISO- 27x2	“A”
581 300 1061	External	ISO- 27x2	“B-C”
581 300 1051	Internal	DIN- 26x1.5	“A”
581 300 1053	Internal	DIN - 26 x 1.5	“B-C”
581 300 1055	Internal	ISO - 27 x 2	“A”
581 300 1057	Internal	ISO- 27 x 2	“B-C”

- All parts below are 16cc
- Used on HPV55-02 frame size
- All parts below are Bi-directional (right **or** left handed)

Part number	Suction is :	Porting is :	PTO is :
580 300 1058	External	DIN- 26x1.5	“A”
580 300 1059	External	DIN- 26x1.5	“B-C”
580 300 1060	External	ISO- 27x2	“A”
580 300 1061	External	ISO- 27x2	“B-C”
580 300 1051	Internal	DIN- 26x1.5	“A”
580 300 1053	Internal	DIN- 26x1.5	“B-C”
580 300 1055	Internal	ISO- 27x2	“A”
580 300 1057	Internal	ISO- 27x2	“B-C”

