

This procedure is valid for BPV-01 pumps with CCW (Left-Hand) rotation and Hydraulic-Remote Control

Please note the sketch below which illustrates the difference between a CW and CCW rotation BPV-01 Control. Please note that the difference between the two rotations is with the external plumbing. All components within the controls are the same. It is imperative that you plumb the POR (per the illustration below) for the appropriate pump rotation to insure proper operation of the POR.

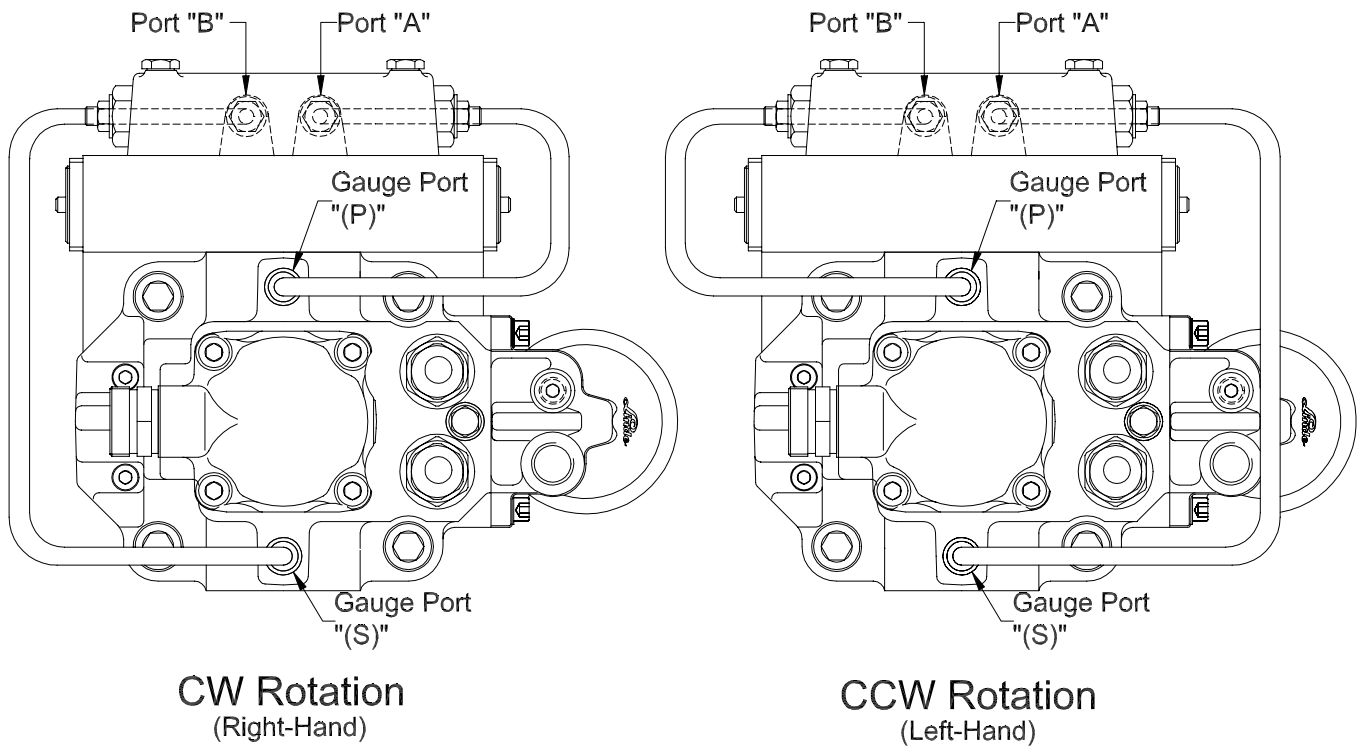

Description of Operation:

The Pressure Override (POR) prevents large amounts of oil from bleeding over the pump's main crossover relief valves (COR), so it reduces the overheating of the main loop in a closed loop application. The POR reduces the control pressure of the pump so that the pump can stroke back towards neutral at a pre-determined maximum system pressure. Valves I and II set the system pressure when the POR becomes active. Valve III sets the flow bleeding over the COR by establishing a minimum control pressure supplied to the pump servo control once the POR is active.

Control Pressure

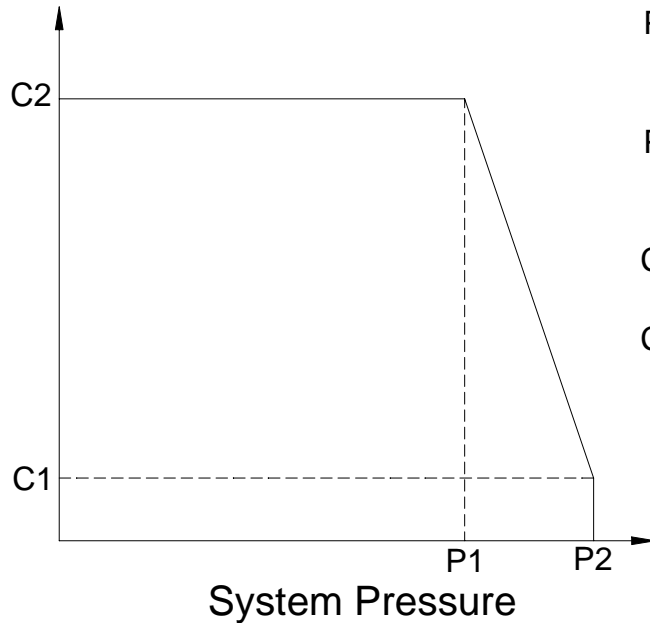

P1 = System Pressure at Maximum Flow
(POR Inactive)

P2 = System Pressure at Minimum Flow
(POR Fully Active)

C1 = Control Pressure at Minimum Flow

C2 = Control Pressure at Maximum Flow

Notes:

- Since the oil is being bled over the COR during this procedure, monitor the oil temperature in the main loop to avoid over heating.
- Oil Temperature Limitations for Linde Components: (-68)°F to 194°F
(-20) °C to 90°C
- Viscosity Limitations for Linde Components: 45 SUS (6 cSt) minimum viscosity
5000 SUS (1000 cSt) maximum viscosity
intermittent for cold starts
- Changes to any pump setting, control supply pressure, or system hardware after the POR has been adjusted could alter the performance of the POR. It may be necessary to readjust the POR to compensate for any of these changes.
- Recommended Gauges:
 - (Qty 2) Liquid-filled gauges, 7,500 psi with 1000 psi major increments and 100 psi minor increments
 - (Qty 1) Liquid-filled Δp gauge, 0-125 psi full scale, 10 psi major increments and 2 psi minor increments

Pump Schematic:

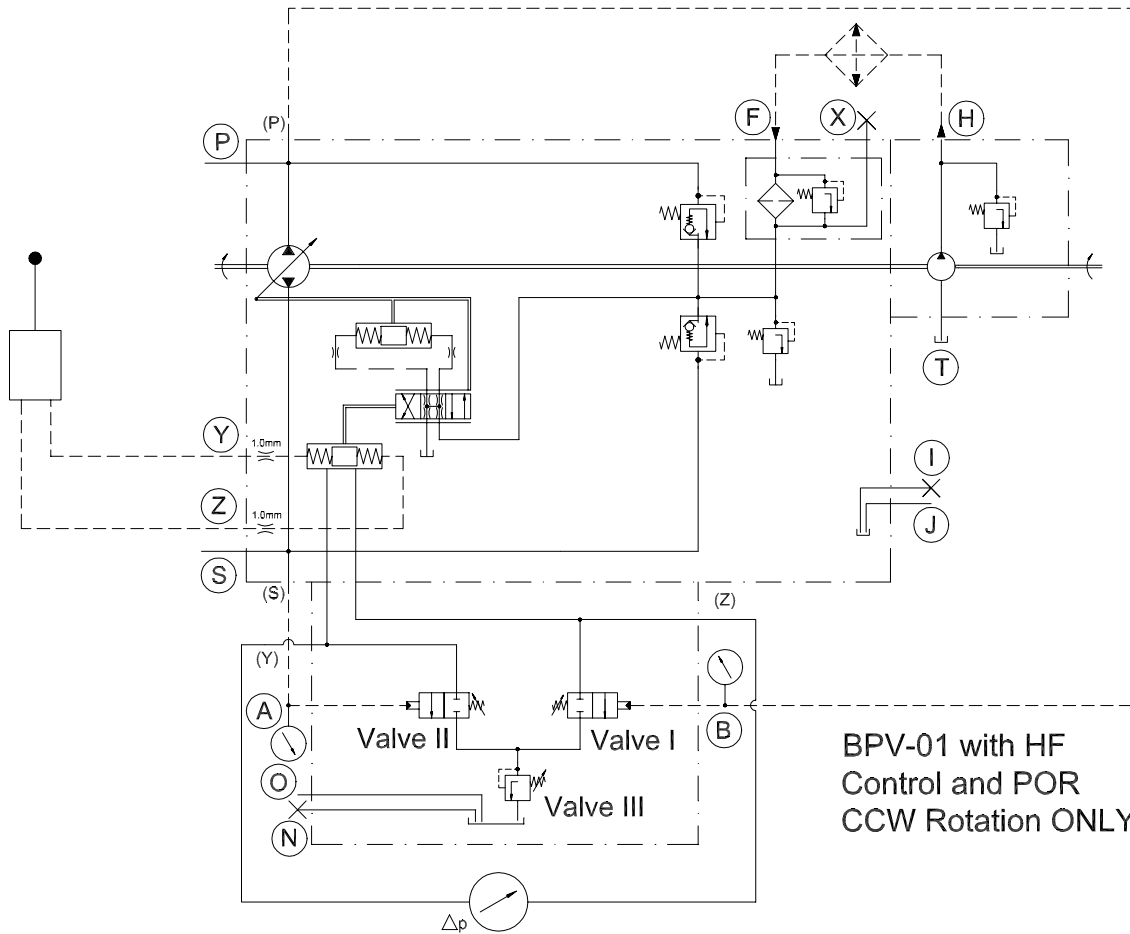

BPV-01 with HF
Control and POR
CCW Rotation ONLY

Port Identification and Adjustment Locations:

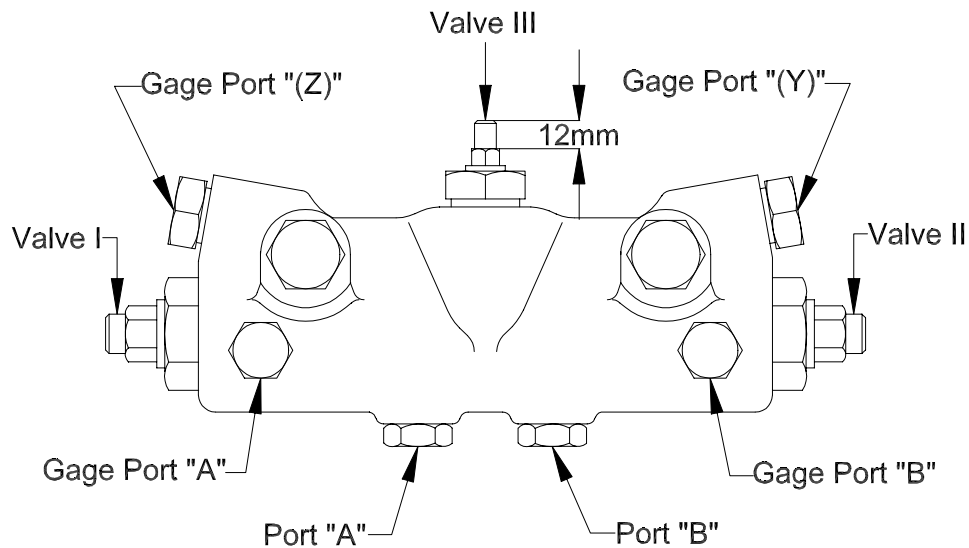

Additional Port Information:

For CCW (Left-Hand) Rotation BPV:

Control Pressure into port "Y".....Pressure from port "S".....Adjust Valve II
Control Pressure into port "Z".....Pressure from port "P".....Adjust Valve I

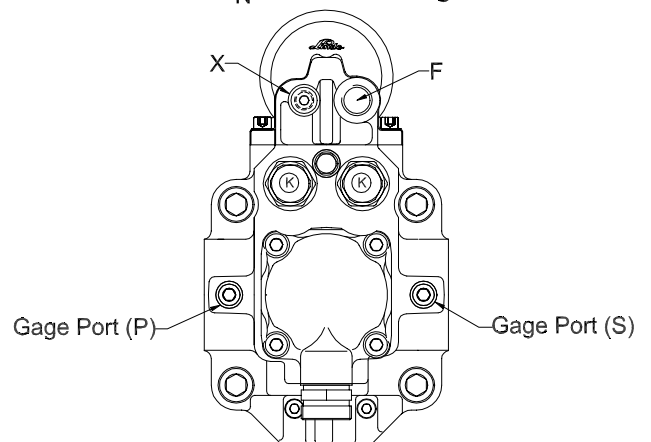
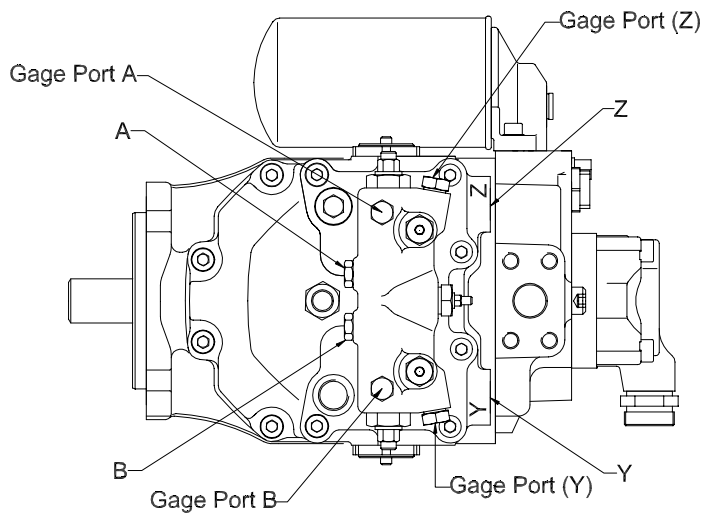
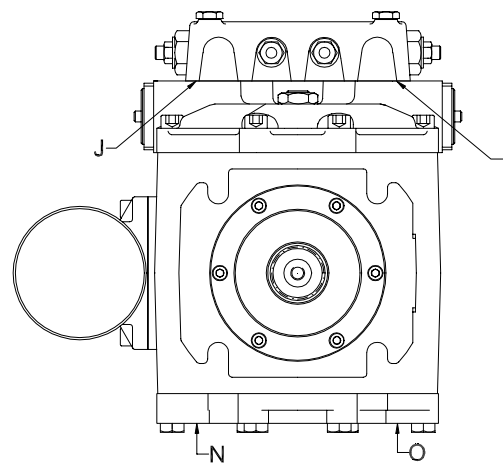
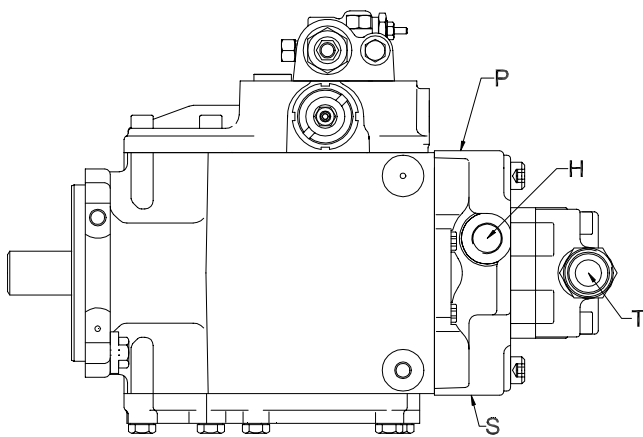

POR Adjustment Procedure:

1. Pre-Adjustments and Setup:

- A. Check for correct pump Regulation Begin setting and Hydraulic Neutral.
- B. Make sure that all supplemental relief valves in the circuit are set **higher** than the COR setting on the pump.
- C. Turn **IN** the adjustment screws for Valves I and II until the ends of the screws are flush with the locking nuts.
- D. Turn **OUT** the adjustment screw for Valve III **no more than** 12mm as illustrated on page 3.
- E. Connect the two 0-7500 psi liquid-filled gauges to pump gauge ports "A" and "B" as shown in the schematic.

2. Preliminary Readings:

- A. Close OFF pump discharge for both "P" and "S" workports.
- B. Connect the "HI" side of the Δp gauge to port "(Y)" and the "LO" side to port "(Z)".
- C. Slowly increase the control pressure to port "Y" and monitor the pump output pressure at port "A". Continue to increase "Y" pressure until the pump output pressure suddenly increases.
- D. Record the Δp_1 control pressure when the pressure at "A" increases:

Δp_1 Pressure = _____ psi

- E. Add 4.5 psi to the Δp_1 pressure recorded above:

New Δp_1 Pressure = _____ psi

- F. Connect the "HI" side of the Δp gauge to port "(Z)" and the "LO" side to port "(Y)".
- G. Slowly increase the control pressure to port "Z" and monitor the pump output pressure at port "B". Continue to increase "Z" pressure until the pump output pressure suddenly increases.

H. Record the Δp_2 control pressure when the pressure at “B” increases:

Δp_2 Pressure = _____ psi

I. Add 4.5 psi to the Δp_2 pressure recorded above:

New Δp_2 Pressure = _____ psi

1. Final Adjustments:

Part 1: Valve I Final Adjustment

- A. Close OFF pump discharge for both “P” and “S” workports.
- B. Turn **OUT** the adjustment screw for Valve I and Valve II

Warning: Care should be taken NOT to remove the adjustment screw in Valves I and II completely. Do NOT turn **OUT** the adjustment screw more than 19mm as illustrated below:

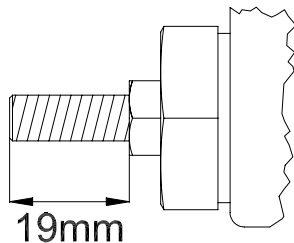

- C. Connect the “HI” side of the Δp gauge to port “(Z)” and the “LO” side to port “(Y)”.
- D. Slowly increase the “Z” control pressure to its maximum value and hold it.
- E. The Δp pressure should be less than the Δp_2 value from step #2H above. IF NOT, STOP AND REPEAT ALL PREVIOUS STEPS.
- F. Turn **IN** the adjustment screw for Valve I until the Δp is the same as the “new Δp_2 ” value recorded in step #2I above.
- G. Tighten the locking nut on Valve I and release the control pressure to port “Z”.

Part 2: Valve II Final Adjustment

- A. Connect the “HI” side of the Δp gauge to port “(Y)” and the “LO” side to port “(Z)”.
- B. Slowly increase the “Y” control pressure to its maximum value and hold it.
- C. The Δp pressure should be less than the Δp_1 value from step #2D above. IF NOT, STOP AND REPEAT ALL PREVIOUS STEPS.
- D. Turn **IN** the adjustment screw for Valve II until the Δp is the same as the “new Δp_1 ” value recorded in step #2E above.
- E. Tighten the locking nut on Valve II and release the control pressure to port “Y”.

Part 3: Valve III Final Adjustment

- A. Connect the “HI” side of the Δp gauge to port “(Y)” and the “LO” side to port “(Z)”.
- B. Slowly increase the “Y” control pressure to its maximum value and hold it.
- C. Turn **IN** the adjustment screw for Valve III until the Δp increases by 1.5 ± 1.5 psi above the “new Δp_1 ” value recorded in step #2E above.
- D. Tighten the locking nut on Valve III and release the control pressure to port “Y”.
- E. Remove all test gauges from the pump.