

This is a "field adjustment" procedure valid for BPV-01 pumps with CW (Right-Hand) rotation and Electro-Hydraulic Remote Control

Please note the sketch below which illustrates the difference between a CW and CCW rotation BPV-01 Control. Please note that the difference between the two rotations is with the external plumbing. All components within the controls are the same. It is imperative that you plumb the POR per the illustration below, for the appropriate pump rotation, to ensure proper operation of the POR.

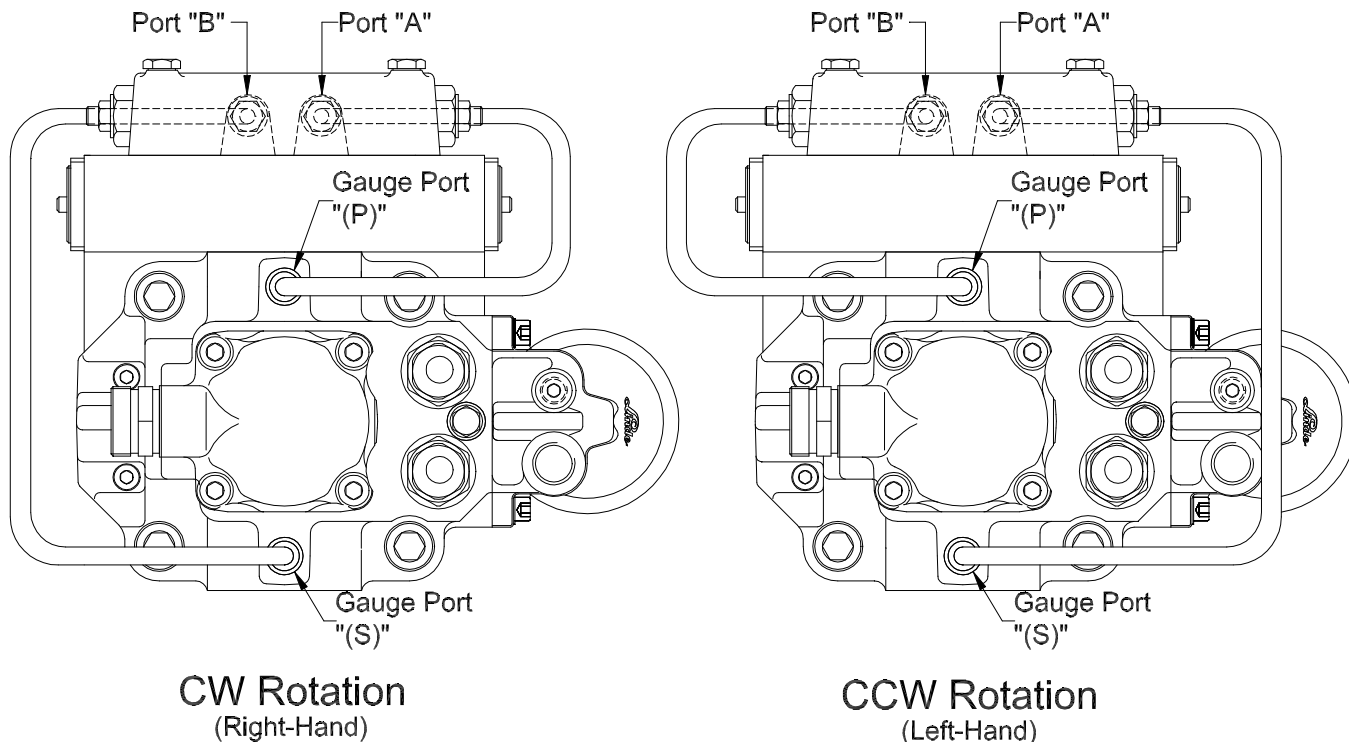

Notes:

- Since the oil is being bled over the main relief valves during this procedure, monitor the oil temperature in the main loop to avoid over heating.
- Oil Temperature Limitations for Linde Components: (-4)°F to 194°F
(-20)°C to 90°C
- Changes to any pump setting, control supply pressure, or system hardware after the POR has been adjusted could alter the performance of the POR. It may be necessary to readjust the POR to compensate for any of these changes.
- Recommended Gauges:
 - (Qty 1) 7,500 psi Liquid-filled gauge (Qty 2 recommended for ease of testing)
 - (Qty 1) 0-200 psi Δp -gauge or Δp -transducer

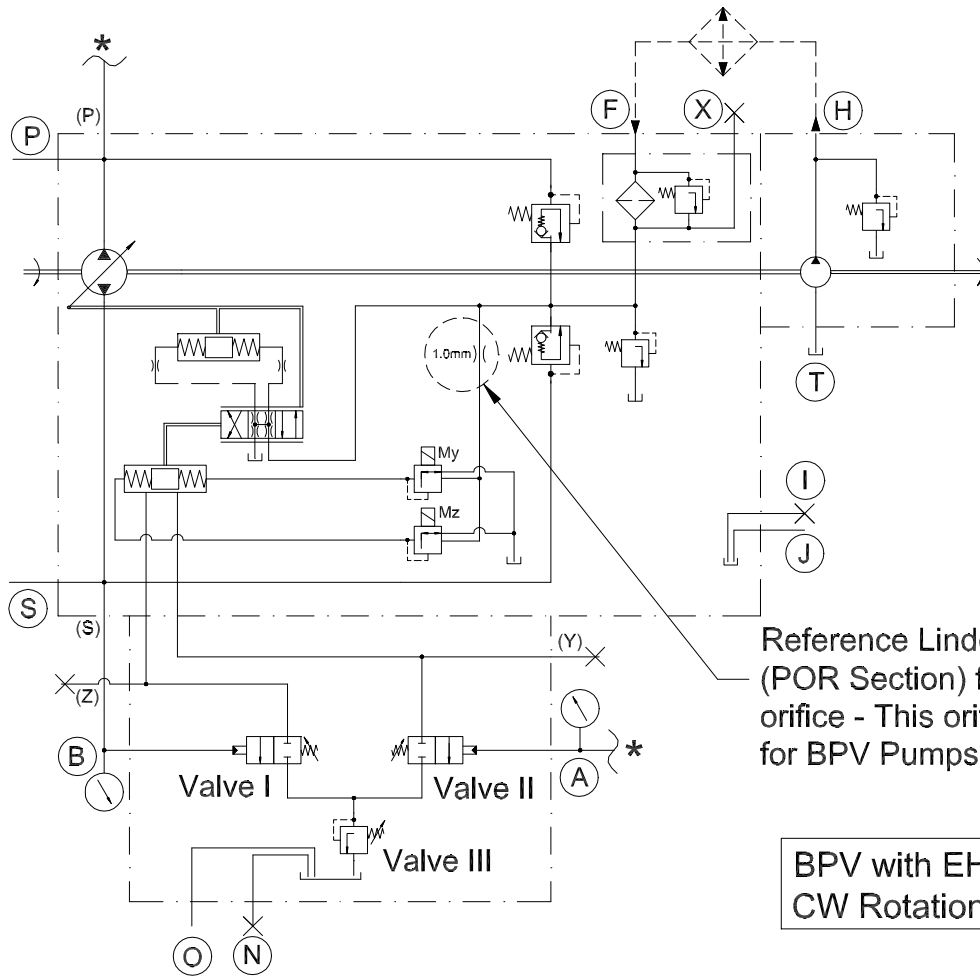

Port Identification and Adjustment Locations:

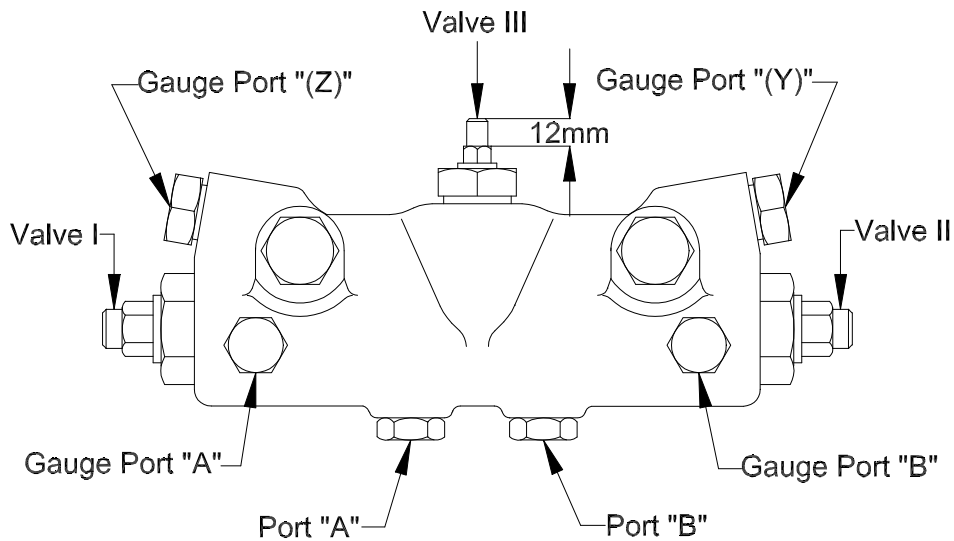

Additional Port Information:

For CW (Right-Hand) Rotation BPV:

Energize Solenoid "My".....Pressure from port "P".....Adjust Valve II

Energize Solenoid "Mz".....Pressure from port "S".....Adjust Valve I

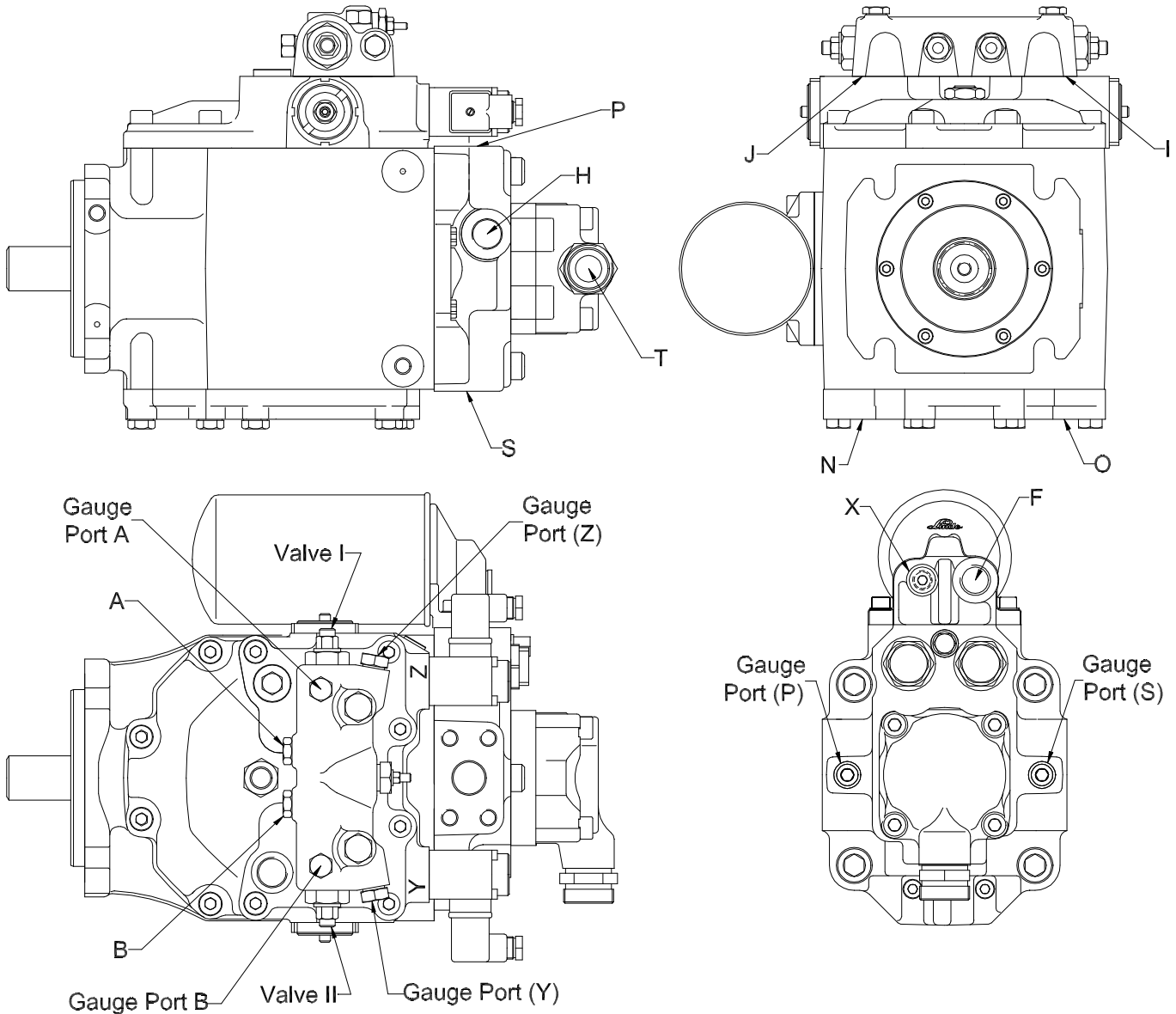

POR Adjustment Procedure:

1. **Pre-Adjustments and Setup:**

- A. Check for correct pump Regulation Begin setting and Hydraulic Neutral.

Record "Y" Regulation Begin Pressure: _____ psi

Record "Z" Regulation Begin Pressure: _____ psi

- B. Make sure that all supplemental relief valves in the circuit are set **higher** than the main relief valves on the pump.
- C. Turn **OUT** the adjustment screw for Valve III **no more than** 12mm as illustrated on page 2.
- D. Turn **OUT** the adjustment screw for Valve I and Valve II

Warning: Care should be taken **NOT** to remove the adjustment screw in Valves I and II completely. Do **NOT** turn **OUT** the adjustment screw more than 19mm as illustrated below:

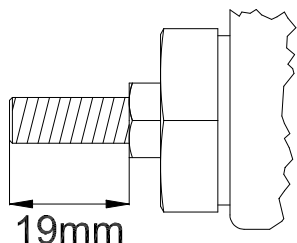

- E. Connect the two 0-7500 psi liquid-filled gauges to pump gauge ports "A" and "B" as shown in the schematic.
- F. Be sure to install the 1.0mm orifice as specified in the schematic on page 2, before continuing with this procedure.
2. **Final POR Adjustments:**

Part 1: Valve I Final Adjustment

- A. Close OFF pump discharge for both "P" and "S" workports.
- B. Fully energize solenoid "Mz" to its maximum value and hold it.

Note: System pressure will be unstable - This is an expected pump reaction.

- C. While monitoring the pressure-gauge at port "B", *SLOWLY* turn the adjustment screw for Valve I **IN** until the pressure just stabilizes.

IMPORTANT

You must slowly turn the adjustment screw in ONLY until the pressure stabilizes and then stop. If you continue to turn the adjustment screw in, system pressure will continue to increase and an unnecessary amount of oil will be forced over the main relief valve, thus the operation of the POR will become less efficient.

- D. Tighten the locking nut on Valve I and de-energize solenoid "Mz".

Part 2: Valve II Final Adjustment

- A. Fully energize solenoid "My" to its maximum value and hold it.

Note: System pressure will be unstable - This is an expected pump reaction.

- B. While monitoring the pressure-gauge at port "A", *SLOWLY* turn the adjustment screw for Valve II **IN** until the pressure just stabilizes.

IMPORTANT

You must slowly turn the adjustment screw in ONLY until the pressure stabilizes and then stop. If you continue to turn the adjustment screw in, system pressure will continue to increase and an unnecessary amount of oil will be forced over the main relief valve, thus the operation of the POR will become less efficient.

- C. Tighten the locking nut on Valve II and de-energize solenoid "My".

Part 3: Valve III Final Adjustment

- A. Connect the 0-200 psi Δp -gauge to measure control pressure "(Y)".

- B. Fully energize solenoid "My" to its maximum value and hold it.

- C. SLOWLY turn **IN** the adjustment screw for Valve III until control pressure "(Y)" is 10-11 psi higher than the "Y" Regulation Begin Pressure recorded above.

- D. Tighten the locking nut on Valve III and de-energize solenoid "My".

- E. Connect the 0-200 psi Δp -gauge to measure control pressure "(Z)". Fully energize solenoid "Mz" to its maximum value and hold it. Verify that control pressure "(Z)" is 10-11 psi higher than the "Z" Regulation Begin Pressure recorded above.

Part 4: Final Adjustment

- A. Turn **OUT** the Valve I Adjustment screw $\frac{1}{4}$ turn, then tighten the locking nut (recommended torque is 14 N-m [10 ft-lb]).
- B. Turn **OUT** the Valve II Adjustment screw $\frac{1}{4}$ turn, then tighten the locking nut (recommended torque is 14 N-m [10 ft-lb]).
- C. Fully energize solenoid "My" and verify that the workport pressure is stable.
- D. Fully energize solenoid "Mz" and verify that the workport pressure is stable.

Note:

If either one or both workport pressures are not stable, then slowly turn the adjustment screw for Valve III **IN** until the instability is eliminated.



******* ATTENTION *******

You have been provided information on conversion, repair and/or service of Linde components. Proper application of the information requires specific training and may require use of specialized tooling and equipment. If you choose to proceed with the conversion, repair and/or service of the Linde component(s) absent the necessary training and/or these specialized tools, you do so at your risk.

Linde Hydraulics Corporation will accept no claim for warranty or other consideration resulting from deficiencies in the conversion, repair and/or service done in accordance with the guidance offered herein when the necessary training has not been conducted and/or required specialized tooling and equipment has not been utilized.

All requests for training must be coordinated through your Linde Account Manager. He can also provide you price and availability of any specialized tooling.

Questions regarding the information provided or this disclaimer should be addressed to the Warranty & Service Department, Linde Hydraulics Corporation.

5089 Western Reserve Road
Canfield, OH 44406
330.533.6801 (Telephone)
330.533.9873 (Facsimile)
www.lindeamerica.com (Web Site)