

Tools / Equipment Required

- 12mm Allen wrench
- 13mm Wrench.
- torque wrench capable of setting 122 N-m (90 ft-lb)
- needle-nose pliers
- Plug for blocking the purge valve (P/N 888 304 0230)
- Rubber Mallet.
- Modified Shuttle Spool (P/N 888 303 1020)

Procedure to disable the Shuttle

- 1 Remove the M22 Plug with the 12mm Allen wrench.
- 2 Remove the spring with the needle-nose pliers.
- 3 Remove the Washer and Shuttle Spool simultaneously with the needle-nose pliers.
- 4 Remove the Washer from the Shuttle Spool.

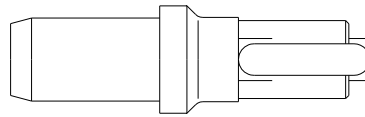

Standard Shuttle Spool

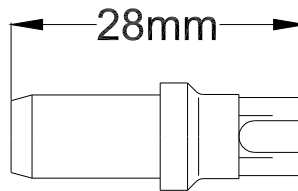

Modified Shuttle Spool
(LHC P/N 8883031020)

- 5 Replace the Standard Shuttle Spool with the Modified Shuttle Spool (illustrated above).

NOTE

You can purchase the Modified Shuttle Spool from Linde by ordering part number 8883031020. Alternately, you can grind down the Standard Shuttle Spool to 28mm as illustrated above. If choosing the grinding method, be warned that this will permanently disable the case flushing feature until a new Standard Shuttle Spool is used.

- 6 Reinstall the Washer onto the Modified Shuttle Spool.
- 7 Reinstall the Washer/Modified Shuttle Spool subassembly back into the Shuttle Body.
- 8 Reinstall the spring.
- 9 Reinstall the M22 Plug. Torque the M22 Plug to 122 N-m (90 ft-lb).

Procedure to disable the Purge Valve

1. Use the 13mm wrench to remove the purge valve.
2. Inspect the o-ring on the purge valve body and replace it if necessary. Refer to LINDOS for correct part number.

3. Install the plug (P/N 888 304 0230) on the purge valves nose as shown here.

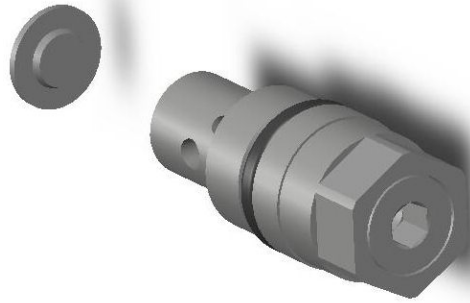

⚠ IMPORTANT

The plug must be seated in position completely. You may have to tap the plug into position using a rubber mallet.

4. Install the purge valve back into the motor and torque it to 15 N-m (11 ft-lb)

ATTENTION

You have been provided information on conversion, repair and/or service of Linde components. Proper application of the information requires specific training and may require use of specialized tooling and equipment. If you choose to proceed with the conversion, repair and/or service of the Linde component(s) absent the necessary training and/or these specialized tools, you do so at your risk.

Linde Hydraulics Corporation will accept no claim for warranty or other consideration resulting from deficiencies in the conversion, repair and/or service done in accordance with the guidance offered herein when the necessary training has not been conducted and/or required specialized tooling and equipment has not been utilized.

All requests for training must be coordinated through your Linde Account Manager. He can also provide you price and availability of any specialized tooling.

Questions regarding the information provided or this disclaimer should be addressed to the Warranty & Service Department, Linde Hydraulics Corporation.

5089 Western Reserve Road
Canfield, OH 44406
330.533.6801 (Telephone)
330.533.9873 (Facsimile)
www.lindeamerica.com (Web Site)